

EXPLORER LE MONDE

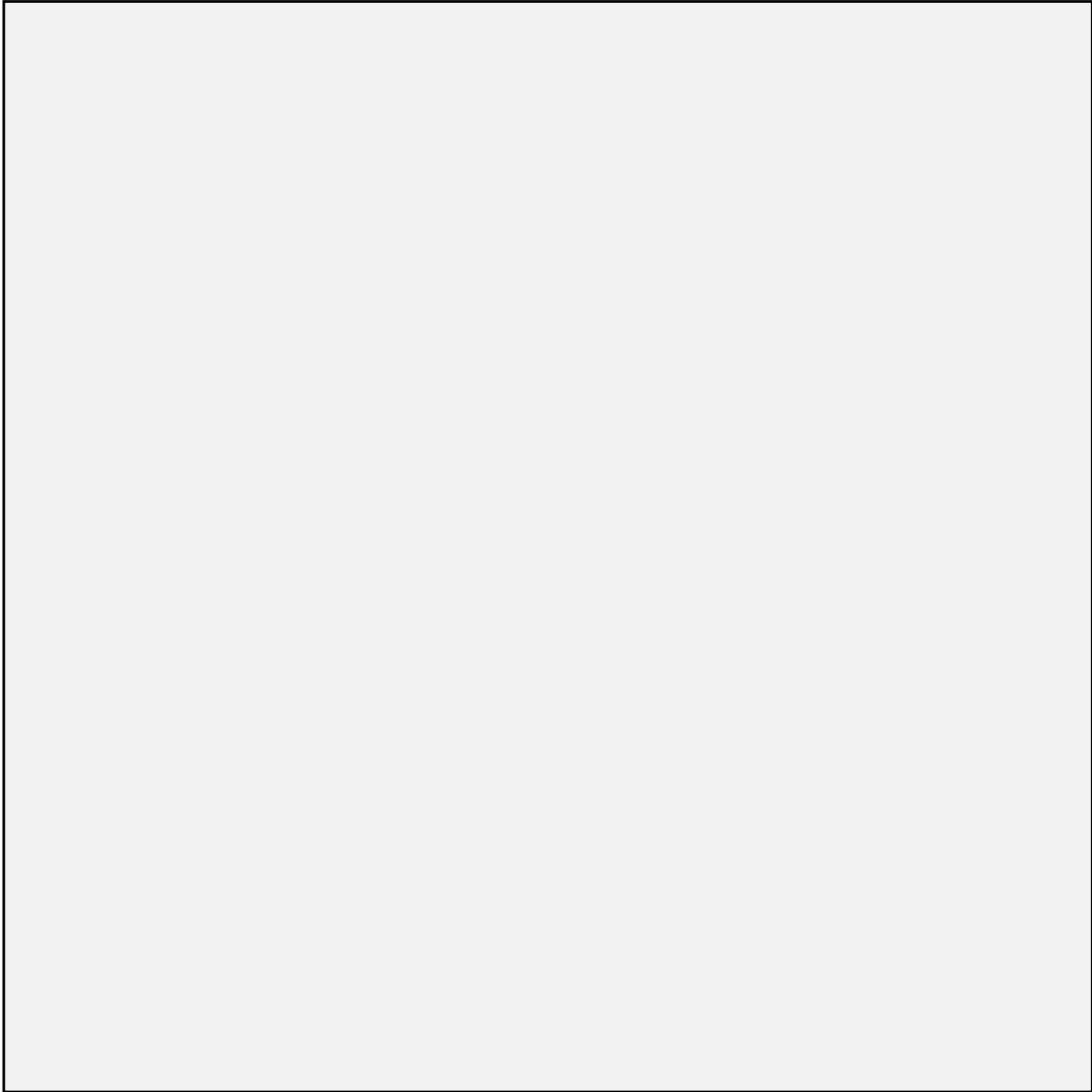

Consigne : reconstitue la couverture de l'album.



Le banc des amis

Valérie Cros
Henrike Wilson

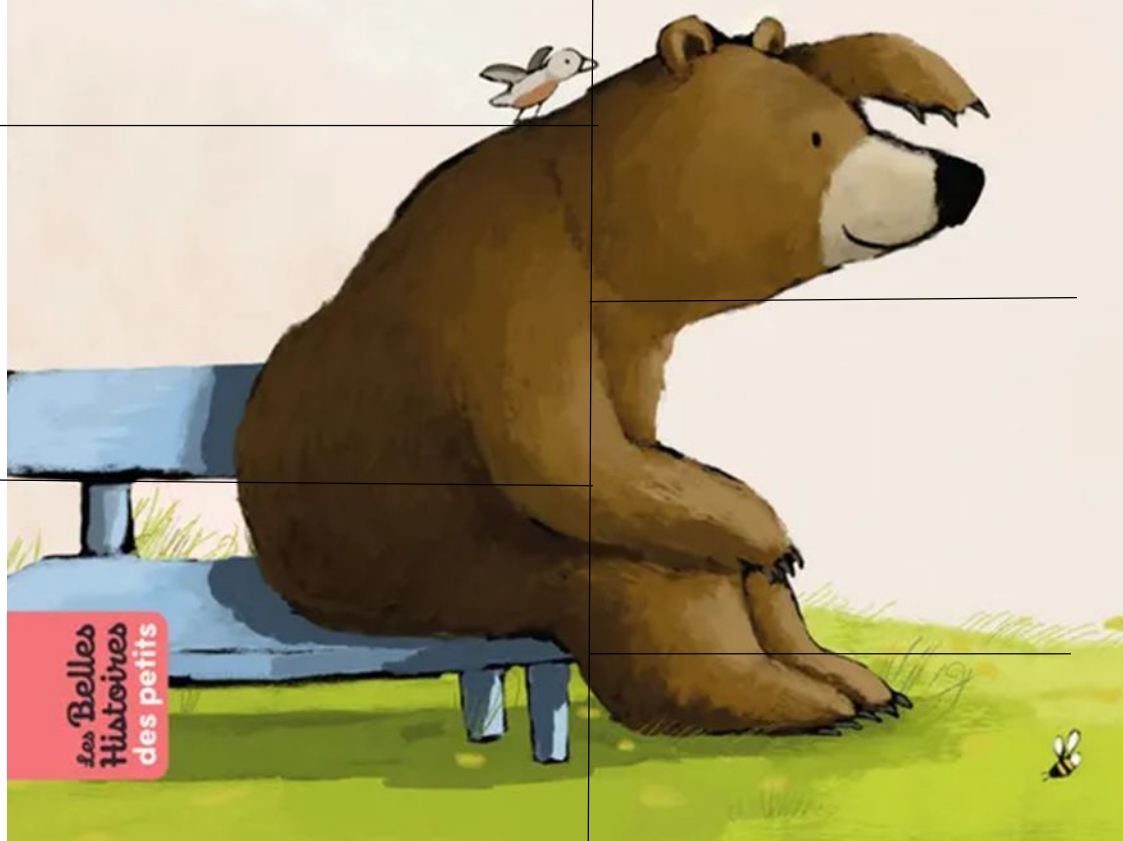

Les Belles
Histoires
des petits

Le banc des amis

Valérie Cros
Henrike Wilson

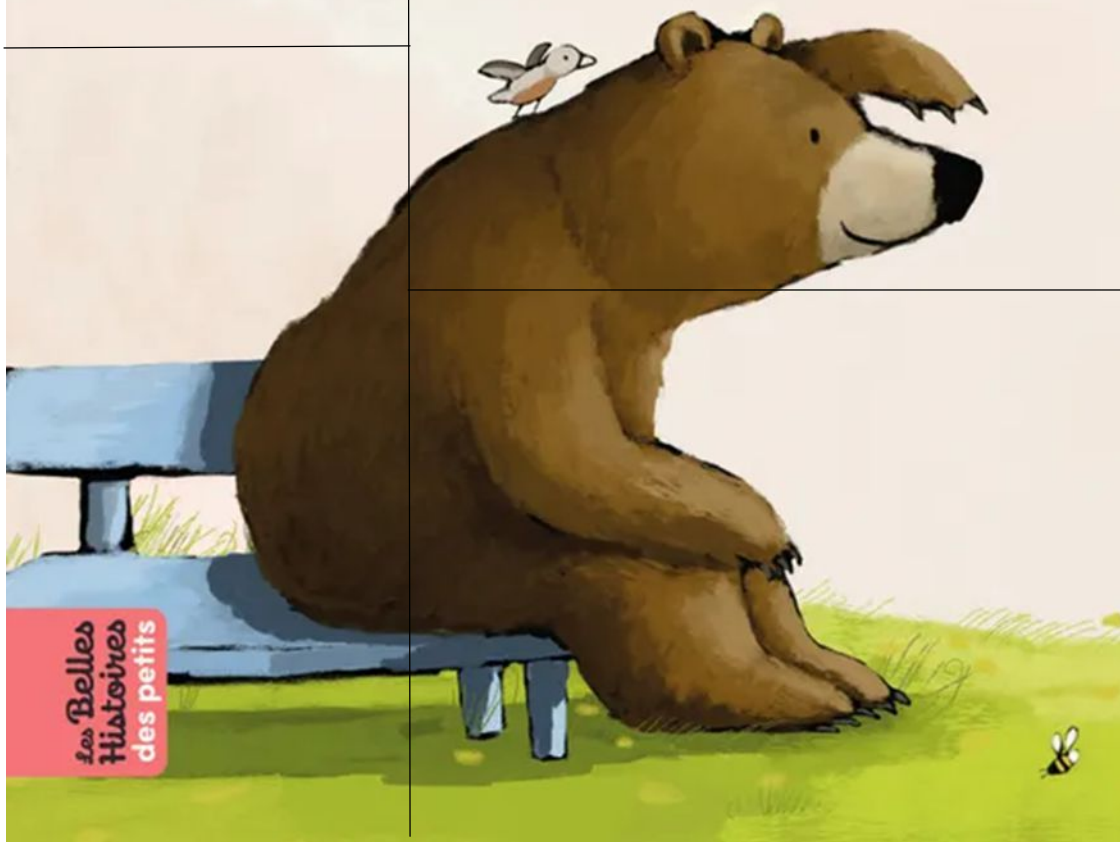

Les Belles
Histoires
des petits

DÉCOUVRIR L'ÉCRIT



Consigne : repasse sur les lettres du mot RENARD puis écris celui-ci entre les lignes.

RENARD

DÉCOUVRIR L'ÉCRIT



Consigne : repasse sur les lettres du mot OURS puis écris celui-ci entre les lignes.

OURS

ECOUTER DE L'ÉCRIT ET LE COMPRENDRE

Le banc
des amis



Consigne : entoure le lieu où se déroule l'histoire.

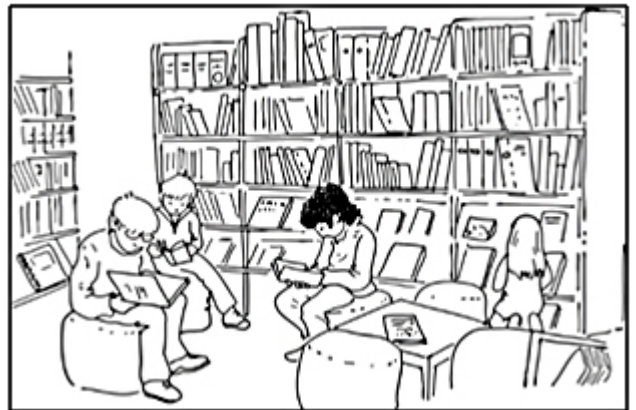
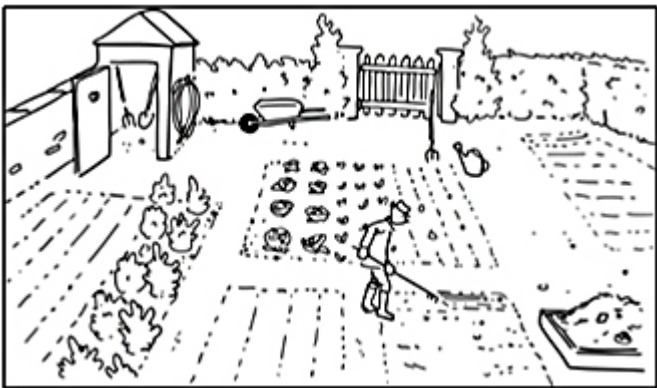

DÉCOUVRIR L'ÉCRIT



Consigne : entoure le mot **AMI**.

BANC

RENARD

AMI

BLAIREAU

AMI

FORÊT

OURS

ARBRE

COLÈRE

GOÛTER

AMI

AMI

DÉCOUVRIR L'ÉCRIT



Consigne : entoure le mot **AMI**.

banc

RENARD

AMI

BLAIREAU

ami

FORÊT

ours

ARBRE

COLÈRE

goûter

AMI

ami

DÉCOUVRIR L'ÉCRIT



Consigne : découpe les étiquettes puis reconstitue le titre.

LE	BANC	DES	AMIS



LE	BANC	DES	AMIS
-----------	-------------	------------	-------------



Consigne : découpe les étiquettes puis reconstitue le titre.

LE	BANC	DES	AMIS

le	banc	des	amis
-----------	-------------	------------	-------------

DÉCOUVRIR L'ÉCRIT



Consigne : relie les lettres du mot COLÈRE dans l'ordre.

O

L

C

È

E

R



Consigne : entoure les lettres qui permettent d'écrire le mot colère.

P

È

C

O

M

L

V

H

R

E

A

NUMÉRATION



Consigne : colle trois gommettes sur chaque banc.

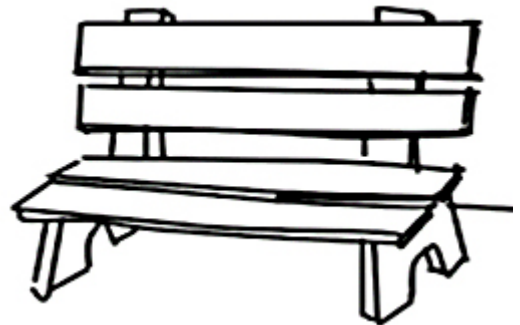
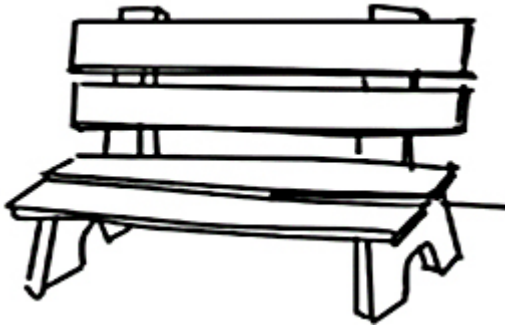
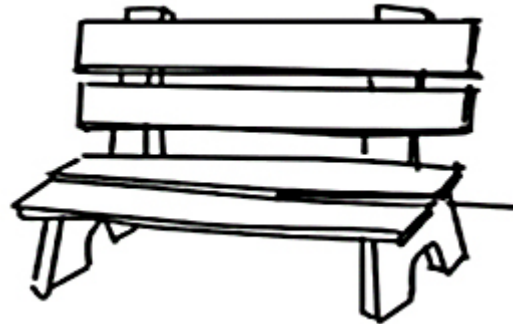
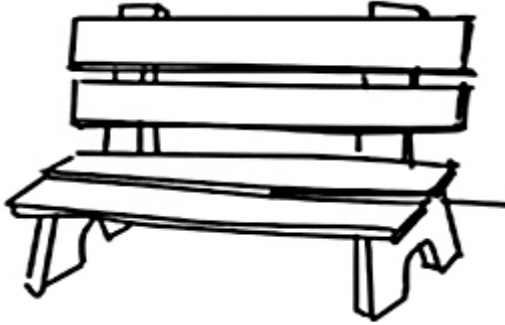

NUMÉRATION



Consigne : colle des gommettes rondes pour qu'il y ait trois ronds sur chaque banc.

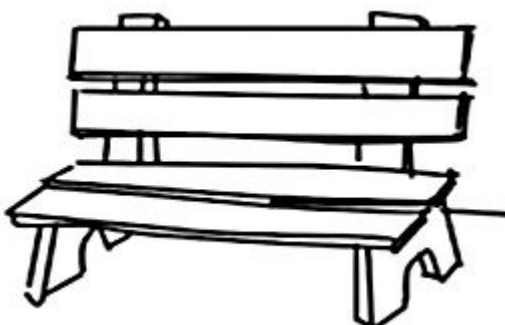
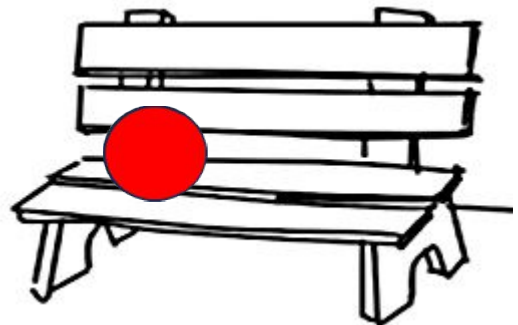
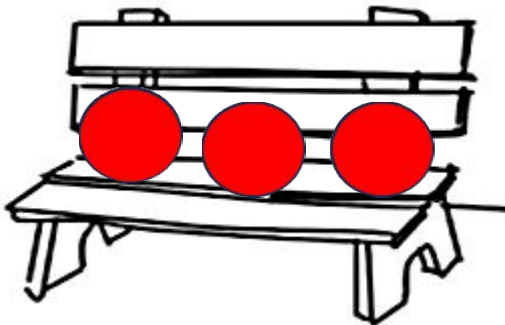
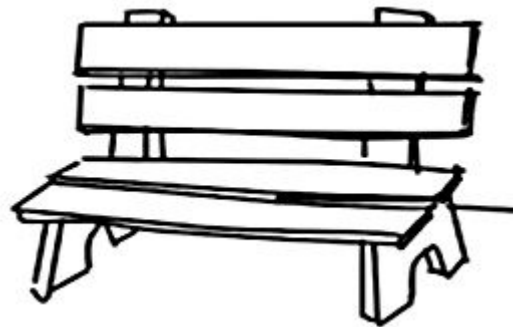
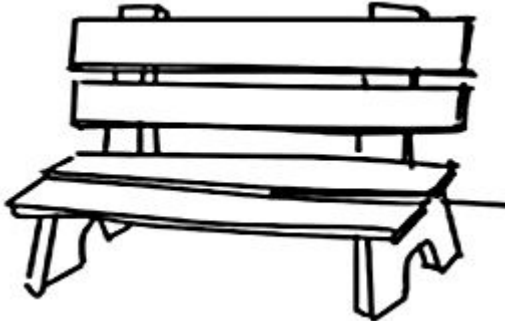

EXPLORER LE MONDE



Consigne : colorie ce qui peut être utilisé par les trois amis pour réparer le banc.

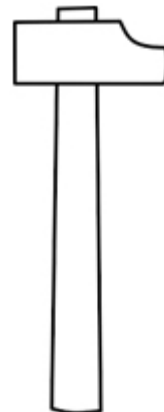
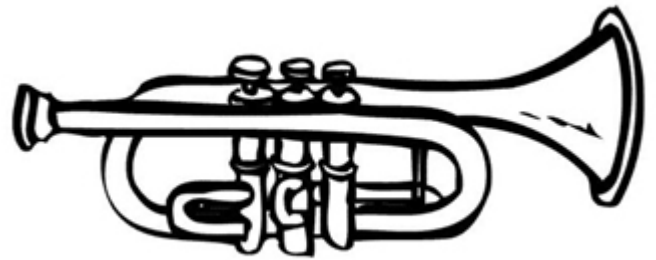
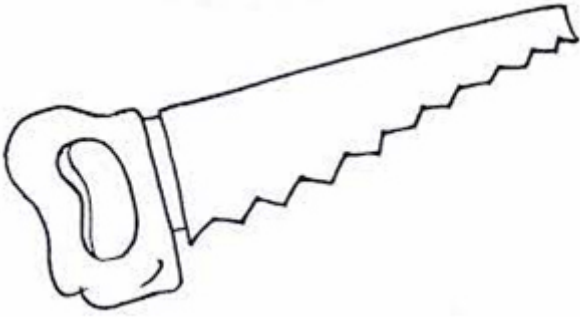

GRAPHISME



Consigne : décore le banc avec les graphismes demandés.

(à compléter pour chaque enfant)

